

FM05MHCR FM05MVCR

DC-5 MBd RedLink® Open Collector Receiver

Data Sheet



DESCRIPTION

The Firecomms DC to 5 MBd Open Collector receiver is based on a fully integrated photodiode with a TIA and limiting amplifier. An internal 1 kΩ resistor (R_L) is available to provide a pull up to the 5 V DC supply rail voltage. This is to support legacy application circuits switching 5 V only.

It operates over an industrial temperature range of -40 °C to +85 °C supporting many industrial applications where reliable command and control response is required in electrically harsh environments.

It is housed in a non-conducting blue plastic connector housing which is flame retardant (UL94V-0). The housings are compatible with the Versatile Link style fiber plug, and are ideal for use with Plastic Optic Fiber (POF) or polymer clad silica (PCS) fiber. It is RoHS and REACH compliant.

NOTE: This part is only suitable for 5V operation. Applications switching 12V/15V should use p/n: FM20VHIR.

AVAILABLE OPTIONS

Option	Part Number
Horizontal Open Collector RedLink® 5 MBd Receiver	FM05MHCR
Vertical Open Collector RedLink® 5 MBd Receiver	FM05MVCR

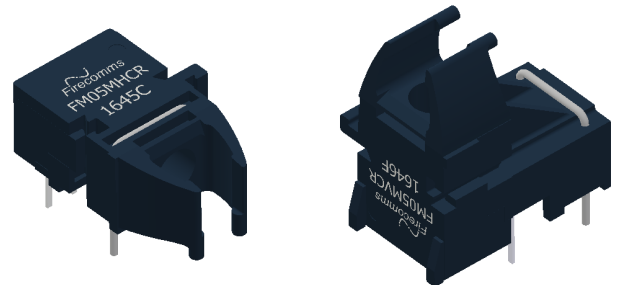

FEATURES

- Open Collector pull up resistor for legacy applications.
- Ideal for use with 1 mm POF and PCS
- Optimized for data transmission from DC to 5 MBd
- Industrial temperature range -40°C to +85°C
- RoHS and UL compliant
- Flame retardant (UL 94 V-0) connector housings
- Low pulse width distortion
- High power supply noise rejection
- Compatible with Versatile Link cables and connectors

APPLICATIONS

Application	Motor Control, Voltage Isolation, Drives, Inverters, Industrial Control, Gaming, Medical Imaging
Standard	Low-speed serial RS232, RS485,
Distance	50 meters Step Index (SI) POF in typical operating conditions 30 meters in worst case conditions
Speed	DC to 5 MBd (NRZ)

SPECIFICATIONS

Table 3
RECEIVER PIN DESCRIPTION

Pin	Name	Symbol
1	Receiver Output	V_o
2	Receiver Ground	Gnd
3	Receiver Vcc	Vcc
4	Open Collector R_L	R_L
5	Retaining Pin	Gnd
8	Retaining Pin	Gnd

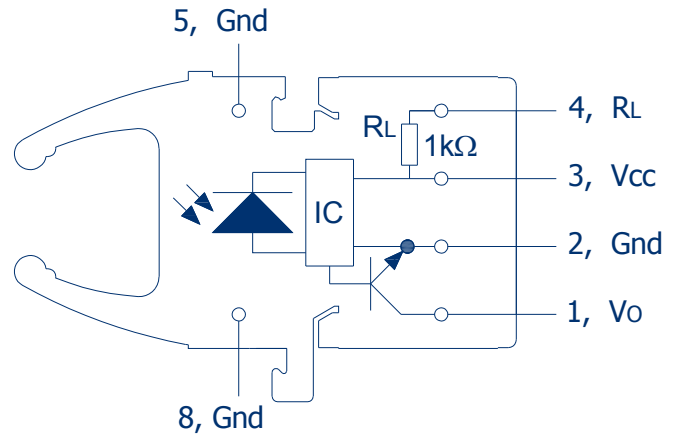

FIGURE 1
Receiver pin-out with Open-Collector, top view

Table 4
REGULATORY COMPLIANCE

Parameter	Symbol	Standard	Level
Electrostatic Discharge, Human Body Model (Contact ESD)	HBM	Mil-STD-883	Level 2 (4 kV)
Radiated Emissions Immunity	Vm^{-1}	IEC 61000-4-3	15 Vm^{-1}
UL Certification	UL	94 V-0 material	Files No. Pending
Storage Compliance	MSL	J-STD-020E	2a (4-week floor life)
Restriction of Hazardous Substances Directive	RoHS	Directive 2011/65/EU	Certified compliant

RECOMMENDED APPLICATION CIRCUIT

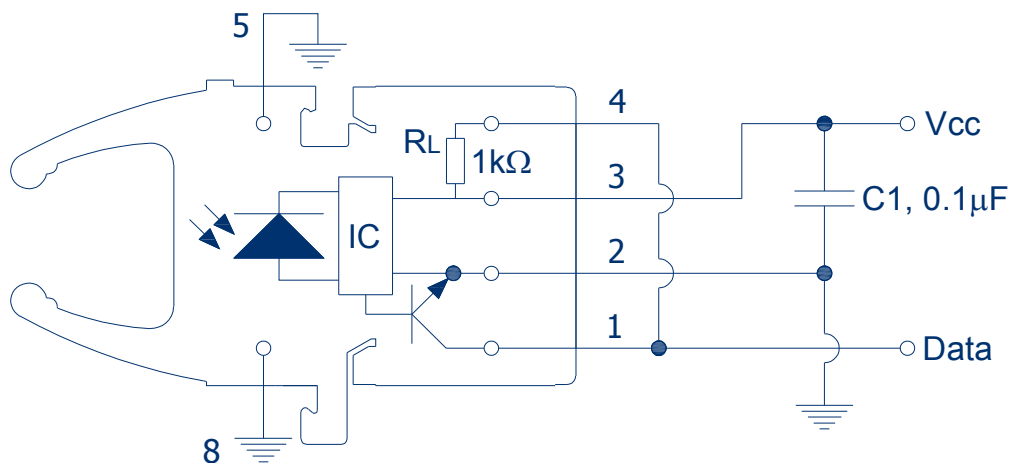

FIGURE 2
RedLink® Open Collector Receiver recommended application circuit.

SPECIFICATIONS

Table 5
ABSOLUTE MAXIMUM RATINGS

These are the absolute maximum ratings at or beyond which the FOT can be expected to be damaged

Notes:

1. 260 °C for 10 seconds, one time only, at least 2.2 mm away from lead root.
2. This is the range of voltages that will not damage the part. It is not the operating range. The correct operating range is $5V \pm 10\%$.
3. This is the maximum load current that can be extracted from V_o or injected into V_o without causing damage to the IC

Parameter	Symbol	Minimum	Maximum	Unit
Storage Temperature	T_{stg}	-40	+85	°C
Operating Temperature	T_{op}	-40	+85	°C
Soldering Temperature ^[1]	T_{sld}		+260 ^[1]	°C
Non-destructive RX Supply Voltage Range ^[2]	Vcc	-0.5	+5.5	V
Output Voltage	V_o	-0.5	+5.5	V
Non-destructive Output Load Current ^[3]	I_o		+25	mA

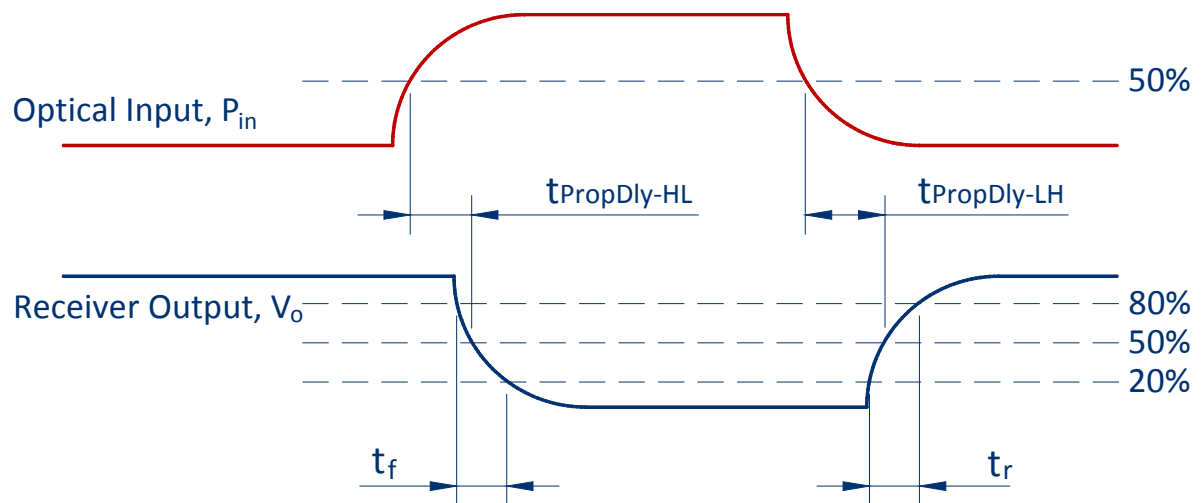

FIGURE 3
Receiver Propagation Delay and rise/fall time definitions

SPECIFICATIONS

Table 6
RECEIVER ELECTRICAL AND OPTICAL CHARACTERISTICS

Test Conditions:

1. Test data was validated over the full temperature range of -40 °C to +95 °C, and over the full voltage range of 4.5 V to 5.5 V unless otherwise noted. Typical data are at +25 °C with $V_{CC} = 5\text{ V}$, in the recommended application circuit.
2. Input power levels are for peak (not average) optical input levels. For 50 % duty cycle data, peak optical power is twice the average optical power. Optical power for POF is measured when coupled into 0.5 m of a 1 mm diameter 0.5 NA fiber and a large area detector.
3. Pins 5 and 8 are for mounting and retaining purposes.
4. In the recommended receiver circuit, with an optical signal from the recommended transmitter circuit.

Parameter	Symbol	Min	Typical	Max	Unit	Test Condition
Input Optical Power Level for Logic "0"	P_{RL}	-22		-1	dBm	$V_{OL} \leq 0.4\text{ V}$ ^[2]
Input Optical Power Level for Logic "1"	P_{RH}			-43	dBm	$V_{OH} \geq 4.45\text{ V}$ $I_{OH} = -40\ \mu\text{A}$ ^[2] ,
Low Level Output Voltage	V_{OL}		0.2	0.4	V	$I_{OL} = 8\text{ mA}$, ^[4]
High Level Output Voltage	V_{OH}			5.5	V	R_L pull up to a maximum allowed voltage rail of 5.5 V
Supply Current (not including R_L)	I_{CC}		13.7	20	mA	$P_R = -1\text{ to }-22\text{ dBm}$
Data Rate		DC		5	MBd	Min UI = 200 ns Max f = 0.5 MHz
Internal Pull-up Resistor	R_L	850	1000	1200	Ω	
Rise Time (20% - 80%)	t_r		27	35	ns	
Fall Time (80% - 20%)	t_f	2	5	10	ns	
Pulse Width Distortion	PWD		20	50	ns	$R_L = 1\text{ k}\Omega$, $C_L = 30\text{ pF}$, Optical Power -1 to -22 dBm
Propagation Delay Low-to-High (OPTO-ELEC, Data/CLK)	$t_{\text{PropDly_LH}}$		60	100	ns	
Propagation Delay High-to Low (OPTO-ELEC, Data/CLK)	$t_{\text{PropDly_HL}}$		49	86	ns	

MECHANICAL DATA, HORIZONTAL

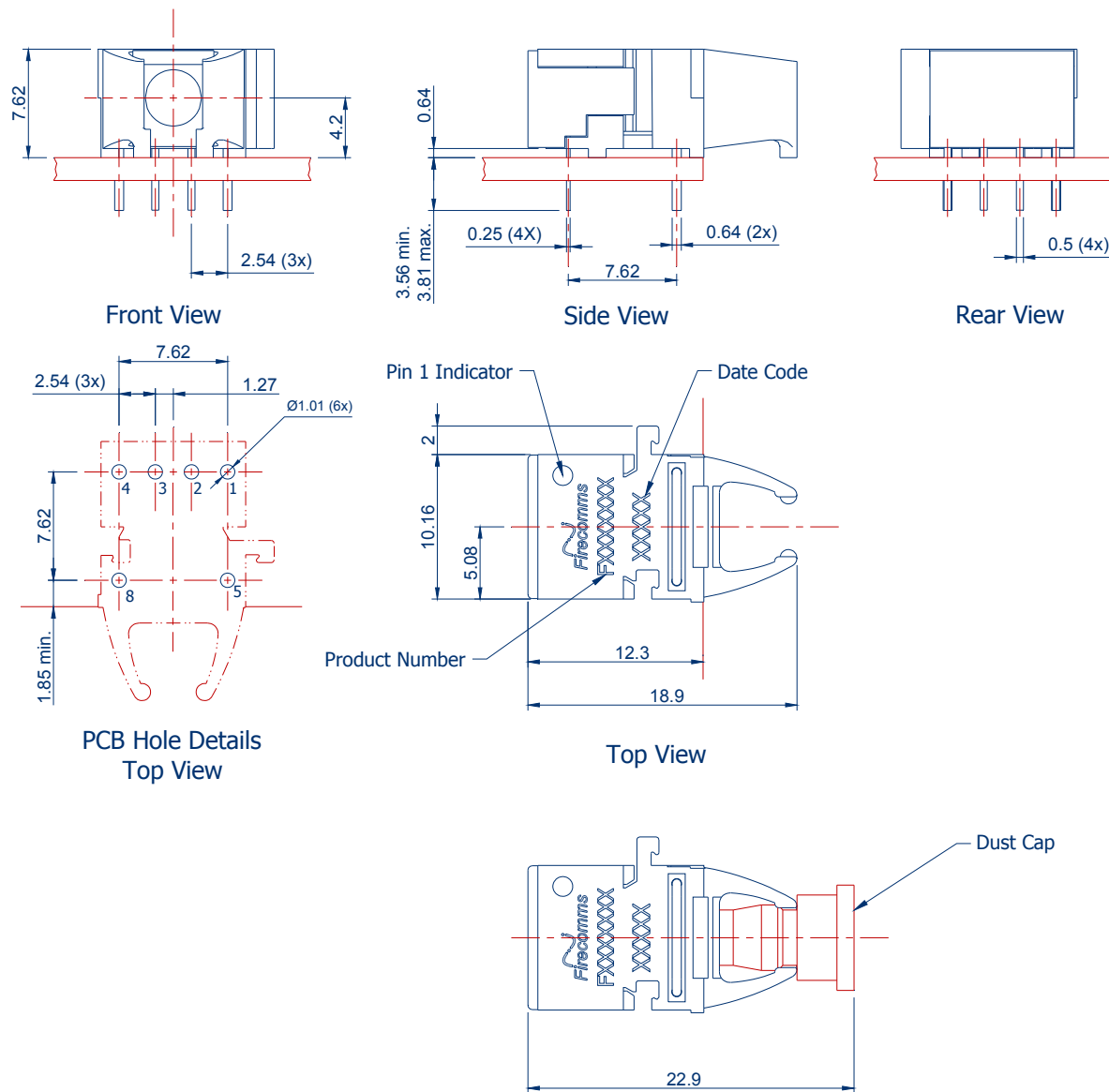

FIGURE 4
Mechanical dimensions of the horizontal connectors and PCB footprint, which is a top view
General dimensional tolerance is ± 0.2 mm

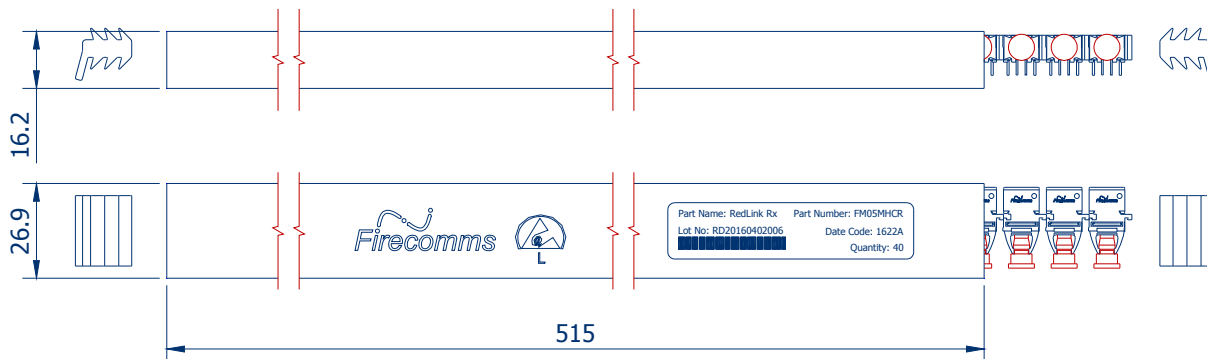

FIGURE 5
Packing tube for Firecomms Horizontal RedLink® Receivers.

MECHANICAL DATA, VERTICAL

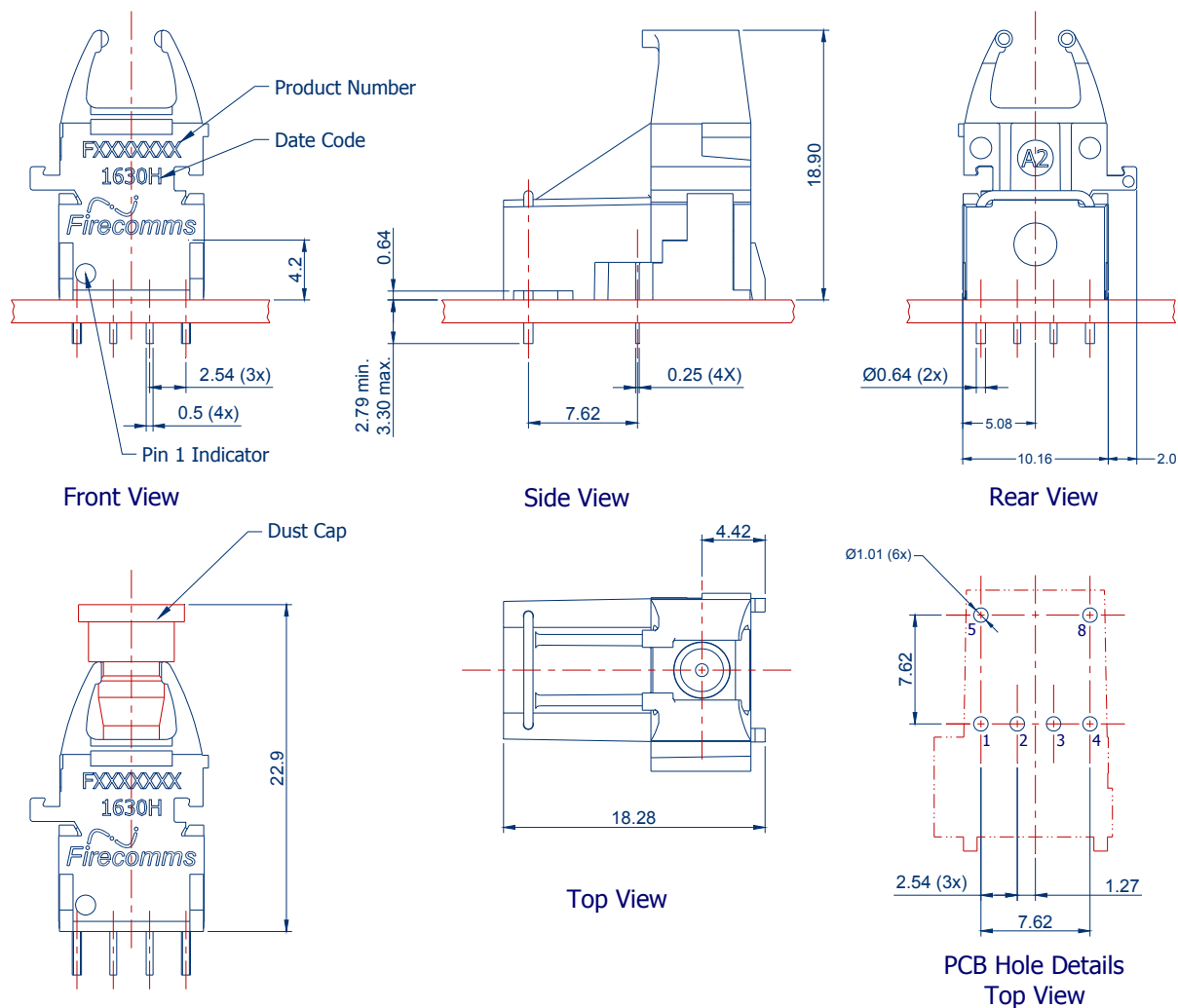

FIGURE 6
Mechanical dimensions of the vertical receiver connectors and PCB footprint, which is a top view
General dimensional tolerance is ± 0.2 mm

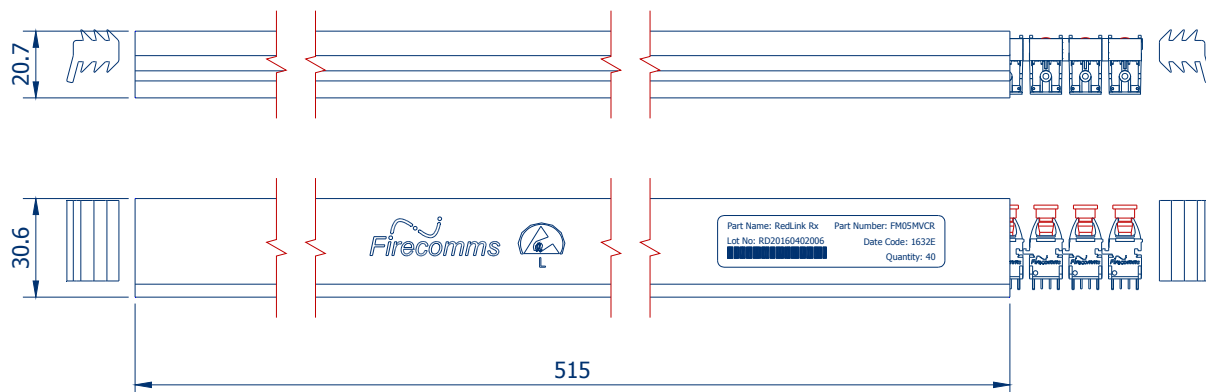

FIGURE 7
Packing tube for Firecomms Vertical RedLink® Receivers.

PART HANDLING

The Firecomms high voltage RedLink® receiver devices are color coded blue. They are auto-insertable. They are tested for handling in static-controlled assembly processes (HBM). Cleaning, degreasing and post solder washing should be carried out using standard solutions compatible with both plastics and the environment. For example, recommended solutions for degreasing are alcohols (methyl, isopropyl and isobutyl). Acetone, ethyl acetate, phenol or similar solution based products are not permitted.

In the soldering process, non-halogenated water soluble fluxes are recommended. These parts are not suitable for use in reflow solder processes (infrared/vapor-phase reflow). The dust plug should remain in place during soldering, washing and drying processes to avoid contamination of the active optical area of each component.

The Moisture Sensitivity Level (MSL) classification of this device is 2a according to JEDEC J-STD-020E. The shelf life of an unopened MBB (Moisture Barrier Bag) is 24 months at < 40 °C and < 90 % R.H. Once the Moisture Barrier Bag is opened the devices can be either

- a) Stored in normal factory conditions < 30 °C and < 60 % R.H. for a maximum of 672 hours (4 Weeks) prior to soldering.
- b) Stored at < 10 % R.H. (Dry Cabinet).

PACKING INFORMATION

Components are packed in PVC anti-static tubes in moisture barrier bags. Bags should be opened only in static-controlled locations, and standard procedures should be followed for handling moisture sensitive components.

Table 7
PACKING INFORMATION

	Horizontal	Vertical
Components per Tube	40	40
Tube Length	515 mm	515 mm
Tube Height	16.2 mm	21.0 mm
Tube Depth	26.9 mm	30.8 mm
Tubes per Bag	5	5
Bags per Inner Carton	1	1
Inner Carton Length	630 mm	630 mm
Inner Carton Width	70 mm	70 mm
Inner Carton Height	105 mm	105 mm
Weight per Inner Carton, Complete	0.77 kg	0.92 kg
Components per Inner Carton	200	200
Inner Cartons per Outer Carton	10	10
Outer Carton Length	650 mm	650 mm
Outer Carton Width	235 mm	235 mm
Outer Carton Height	376 mm	376 mm
Weight per Outer Carton, Complete	8.15 kg	9.61 kg
Components per Outer Carton	2,000	2,000

For the most recent revision or further information please visit www.firecomms.com or contact the company directly at the following address, Firecomms Ltd, 2200 Airport Business Park, Cork, IRELAND. Copyright© 2004-2016 Firecomms. All rights reserved. Firecomms refers to Firecomms Limited and/or its subsidiaries. Firecomms assumes no responsibility for inaccuracies or omissions in the information contained in this document. Specifications are subject to change without notice. No patent rights are granted to any of the circuits described herein.